

Play with the **BEATLES**

# BEATLE

CREATIVE BRIEF.....	02
NAVIGATION MAP.....	03
WIREFRAMES.....	04
STORY BOARD.....	
CREDITS.....	

# BEATLE

**TITLE:** Play with the BEATLES

**COMPANY:** LOSE YOURSELF BE FAMOUS

**PRODUCT:** History book on the BEATLES

**PURPOSE:** TO give a new look on the BEATLES in a fun light hearted way, but at the same time very informational.

**INTERFACE STEPS:**

introduction: Lets go on a magical mystery tour with you and THE BEATLES.

1. Who are the BEATLES.

2. Get to know the BEATLES ( what instruments do they play? )

3. Pick your BEATLES.

4. Learn your BEATLE'S look.

5. The song and words.

6. Your performance with the BEATLES.

**AUDIENCE USER:** 12 and up

**PERCEPTION TONE:** Light Hearted and Fun.

# BEATLE

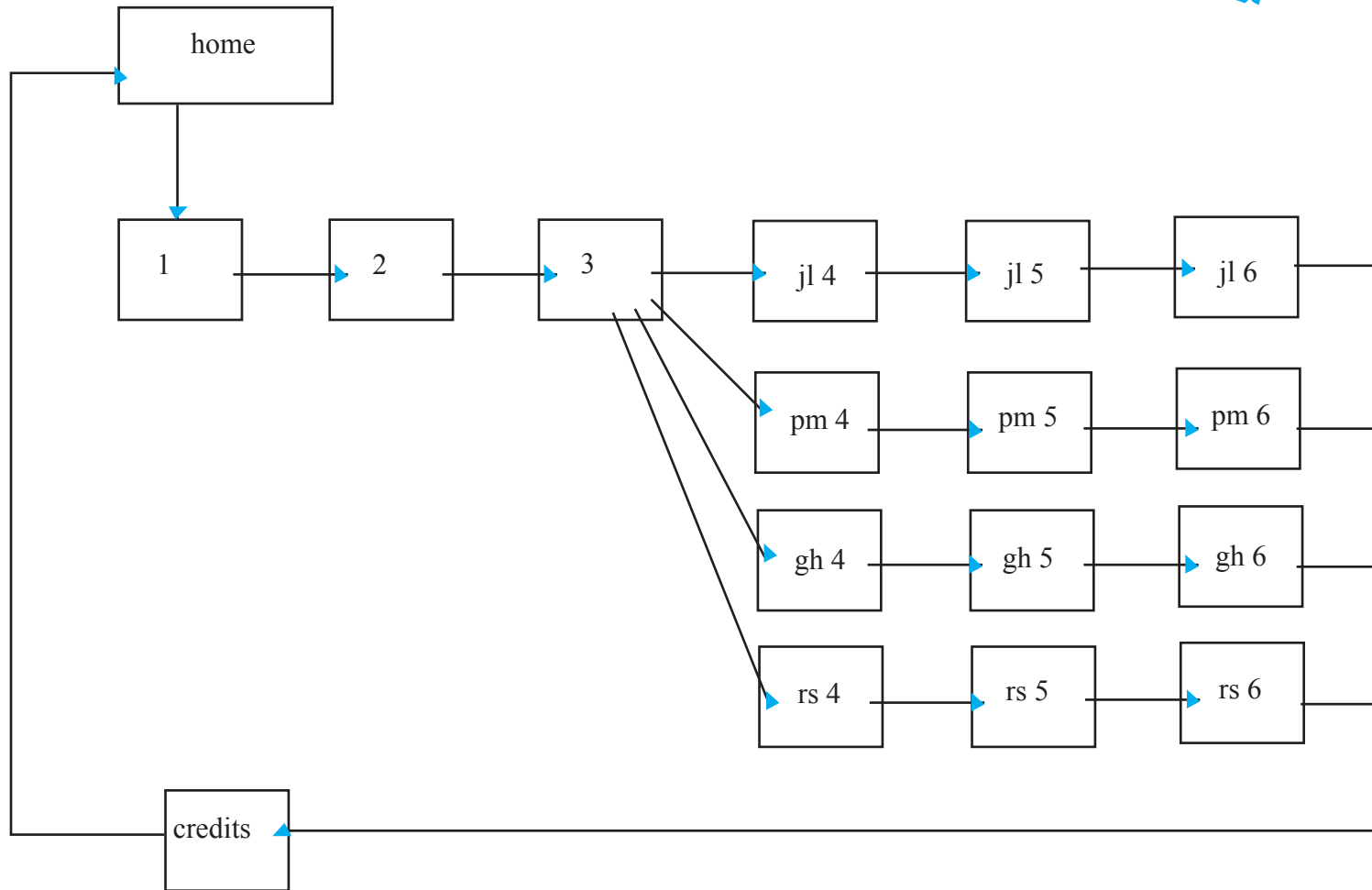

# BEATLE

780

BACKGROUND SHAPE IS  
A FLOWER

INTRO MOVIE OF THE BEATLES PLAYING

lets go on a magical mystery tour with you and  
THE BEATLES

LOGO

585

NEXT

# BEATLE

780

BACKGROUND SHAPE IS  
A FLOWER

MOVIE SHOWING THE DIFFERENT BEALTES

WHO ARE THE BEALTES

NEXT



LOGO

585

# BEATLE

780

BACKGROUND SHAPE IS  
A FLOWER

MOVIE SHOWING WHAT BEATLE PLAYS WHAT INSTRUMENT

LETS GET TO KNOW  
THE BEATLES

NEXT



LOGO

585

# BEATLE

780

BACKGROUND SHAPE IS  
A FLOWER

MOVIE SHOWING THEM PLAYING

BUTTON RS

BUTTON PM

BUTTON GH

BUTTON JL

CHOOSE YOUR BEATLE

NEXT

LOGO

585

# BEATLE

780

BACKGROUND SHAPE IS  
A FLOWER

MOVIE SHOWING THE DIFFERENT BEALTES LOOKS

LOGO

585

LEARN THE LOOK

NEXT

# BEATLE

780

BACKGROUND SHAPE IS  
A FLOWER

MOVIE SHOWING WHAT SONG YOUR BEATLE WILL SING AND  
SOME OF THE WORDS

LOGO

585

LEARN THE SONG AND  
WORDS

NEXT

BEATLE

780

BACKGROUND SHAPE IS  
A FLOWER

MOVIE SHOWING THE BEATLES PLAYING A SONG B

LOGO

585

LETS PLAY

NEXT